



9300 S

Affettatrice verticale / Vertical slicer



OPTIONAL



OPTIONAL



OPTIONAL



DOTAZIONI DI SERIE

- Trasmissione a cinghia
- Affilatoio incorporato di facile impiego
- Grande precisione di taglio
- Altezza di carico ridotta che facilita il lavoro dell'operatore
- Piatto porta merce estraibile con pressa merce in alluminio
- Base di appoggio piedini ridotta
- Affilatoio, coprilama e parafetta asportabili per un'accurata pulizia

OPTIONAL

- Lama 3° generazione
- Pulsanti marcia/arresto IP 69
- Manopole in alluminio

STANDARD EQUIPMENT

- *Belt transmission*
- *Integrated sharpener, friendly use*
- *High precision cutting*
- *Reduced loading height to simplify the operator's daily work*
- *Removable product plate with aluminum product pusher*
- *Reduced cradle feet*
- *Removable sharpener, blade cover and scraper easy cleaning*

OPTIONAL

- *3rd generation blade*
- *IP69 switches: vandal - proof and life time warranty*
- *Aluminium handles*

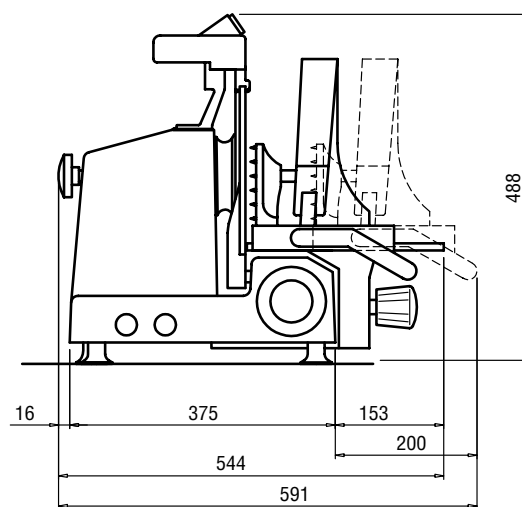
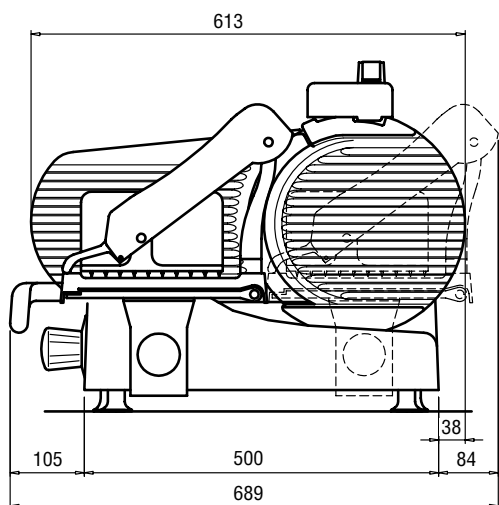

SPECIFICHE TECNICHE - TECHNICAL SPECIFICATION

Diametro lama (mm)	<i>Blade diameter (mm)</i>	300
Motore	<i>Motor</i>	0,37 hp - 0,27 kw
Anello protezione inamovibile	<i>Fixed protection ring</i>	√
Comandi bassa tensione	<i>Low tension devices</i>	√
Blocco meccanico vela spessore	<i>Gauge plate mechanical locking</i>	√
Protezione acqua	<i>Waterproof</i>	IP 54
Normativa riferimento	<i>Reference rule</i>	UNI EN 1974
CAPACITÀ DI TAGLIO - mm	CUTTING CAPACITY - mm	
Rettangolo	<i>Rectangular</i>	220 x 190
Quadrato	<i>Square</i>	190 x 190
Tondo	<i>Round</i>	Ø 200
Apertura max	<i>Max thickness</i>	15
PESO/IMBALLO	WEIGHT / PACKAGE	
Peso netto	<i>Net weight</i>	32,2 kg
Peso imballato	<i>Packed weight</i>	37,2 kg
Dimensioni imballo cartone	<i>Package dimensions cardboard</i>	690 x 710 x 640 ht