



1550 / 1830 / SX 200

Segaossi / Band saws machine



1550 / 1830



SX200



1



2



3

1550 / 1830

DOTAZIONI DI SERIE

- Robuste e facili da usare
- Corpo macchina in metallo fuso finito con verniciature al nitro o anodizzato
- Piano di lavoro in acciaio inox, tendilama registrabile, porzionatore di taglio incorporato
- Motore racchiuso in carcassa con grado di protezione IP 65.
- Con scheda autofrenante a bassa tensione 24V (normativa N.V.R.)

STANDARD EQUIPMENT

- *Heavy duty and friendly use*
- *Cast metal machine frame, nitro painted or anodized*
- *Worktop in stainless steel, adjustable tension pulley, serving setter cuts incorporated*
- *Motor enclosed in casing with IP 65 protection grade, self ventilated and self braking*
- *Low tension board 24V (low N.V.R.)*

SX 200

DOTAZIONI DI SERIE

- Solida e robusta costruzione interamente in acciaio inox
- Pulegge in acciaio inox
- Guidalama superiore scorrevole sostenuta in posizione automatica
- Piano lavoro scorrevole per una pulizia impeccabile
- Piedini regolabili
- Motore e materiale elettrico protetto dagli schizzi d'acqua
- Motore trifase, 230/400V, 50 Hz
- Facile manutenzione e pulizia

STANDARD EQUIPMENT

- *Entirely in stainless steel 18-10, heavy duty and compact*
- *Frame with strong thickness and perfectly rigid*
- *Automatic blade tensioner and serving setter cuts*
- *Sliding upper blade guide with automatic position hold*
- *Four adjustable feet*
- *Waterproof motor and electric equipment*
- *Connection: three phase 230/400V, 50 Hz*
- *Very easy to clean*

1550

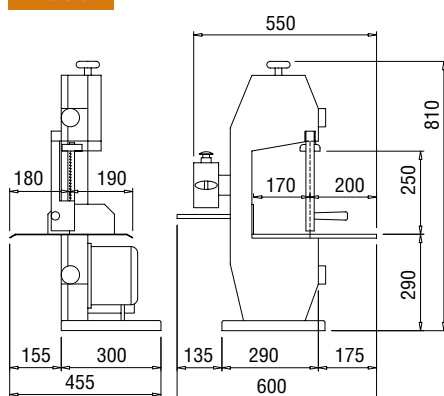

1830

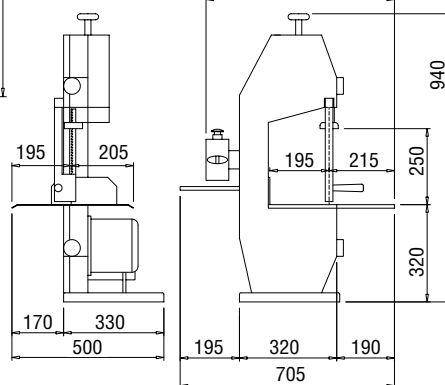

SX200

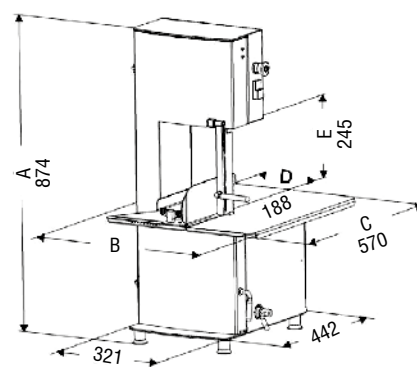

SPECIFICHE TECNICHE / TECHNICAL SPECIFICATION		1550 AL	1830 AL	SX200
Struttura	Frame	Alu	Alu	INOX - SS
Capacità di taglio mm	Cutting capacity mm	170 x 150	225 x 300	190 x 245 ht
Piano lavoro mm	Work top mm	330 x 330	410 x 410	400 x 570
Diametro volani mm	Wheel diam mm	190	200	200
Sviluppo lama mm	Blade standard mm	1550	1830	1640
Motore kw	Motor power kw	0,81	0,81	0,75
Peso kg	Weight kg	34	38	52